

# HH010L

## Payload 10Kgf

Installation method		Application	
Floor	●	Spot welding	
Ceiling		Arc welding	●
Wall surface		Handling	●
		Assembly	
		Sealing	●
		Painting	

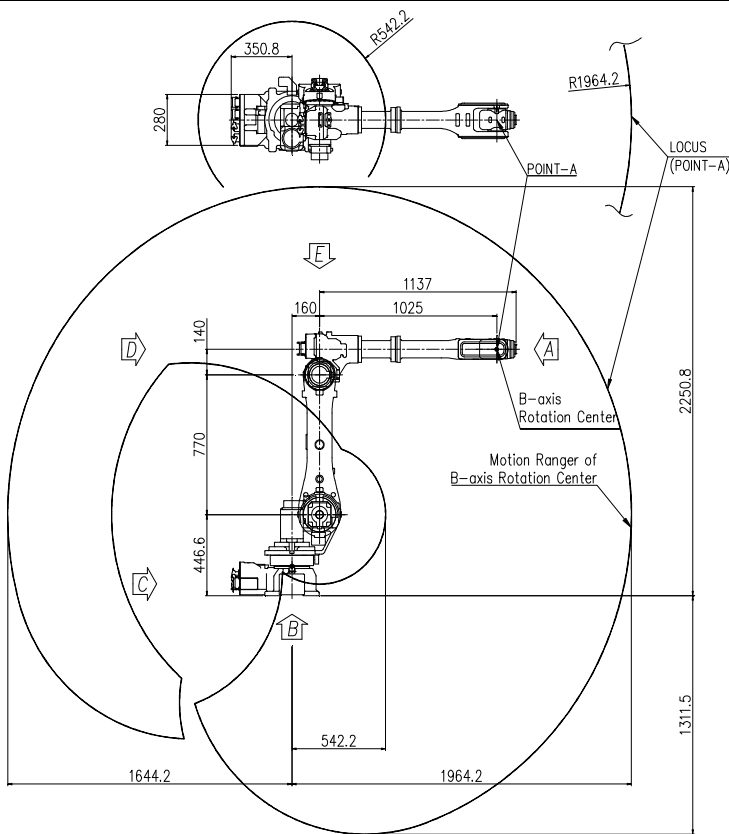

**View A: Detailed drawing of the wrist attachment part**

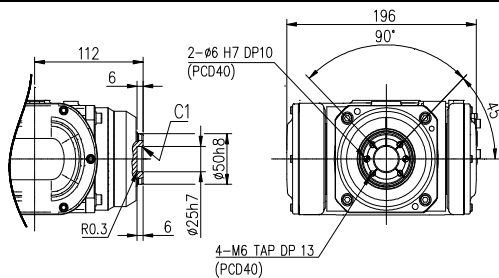

**View B: Dimensional drawing for the floor installation of the body**

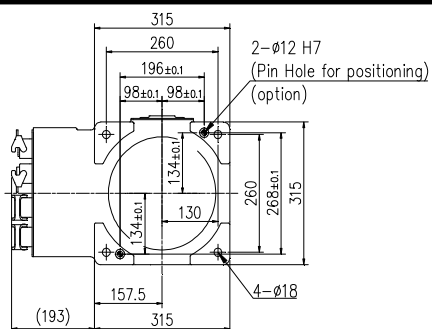

**View C: Application cable connection part (Option)**

**View D: Application cable connection part (Option)**

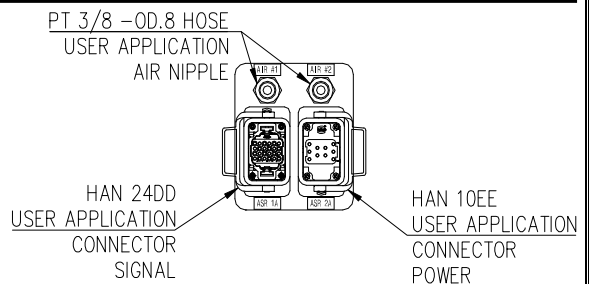

**View E: Details of the application ancillary part attachment**

**Wrist-axis torque line diagram**

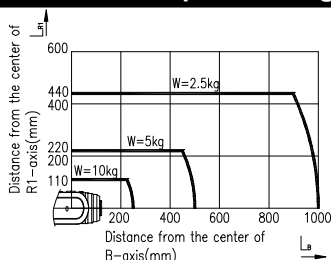

\*\* For product improvement, some of the ratings, specifications, dimensions, etc. are subject to changes without notice.

